S/N: R9B1–Up
S/N: B9C1–Up
S/N: R9C1–Up
S/N: B9D1–4762
S/N: B9E1–1143
S/N: B9F1–Up
S/N: B9G1–Up
S/N: D9G1–1585
S/N: B9H1–Up
S/N: R9H1–Up
S/N: B9J1–Up
S/N: R9J1–Up
S/N: B9L1–Up
S/N: B9M1–Up
S/N: B9N1–Up
S/N: B9R1–Up
S/N: B9T1–Up
S/N: D9T1–1438
S/N: B9W1–Up
S/N: D9W1–Up

The following simplified electrical schematics for the M Series Motor Graders Implement Electronic Control System are electrically correct. The schematics show the input connections and the output connections for the J1 and the J2 connectors on the Implement ECM, the Implement ECM 2, and the Implement ECM 3.

The schematics do not show all possible harness connectors. The schematics do not show all related electrical systems on the machine. For a complete electrical system schematic of a particular machine, always refer to the Electrical System Schematic in the Service Manual for your machine.

Testing and Adjusting

M SERIES IMPLEMENT ECM - J1 CONNECTIONS

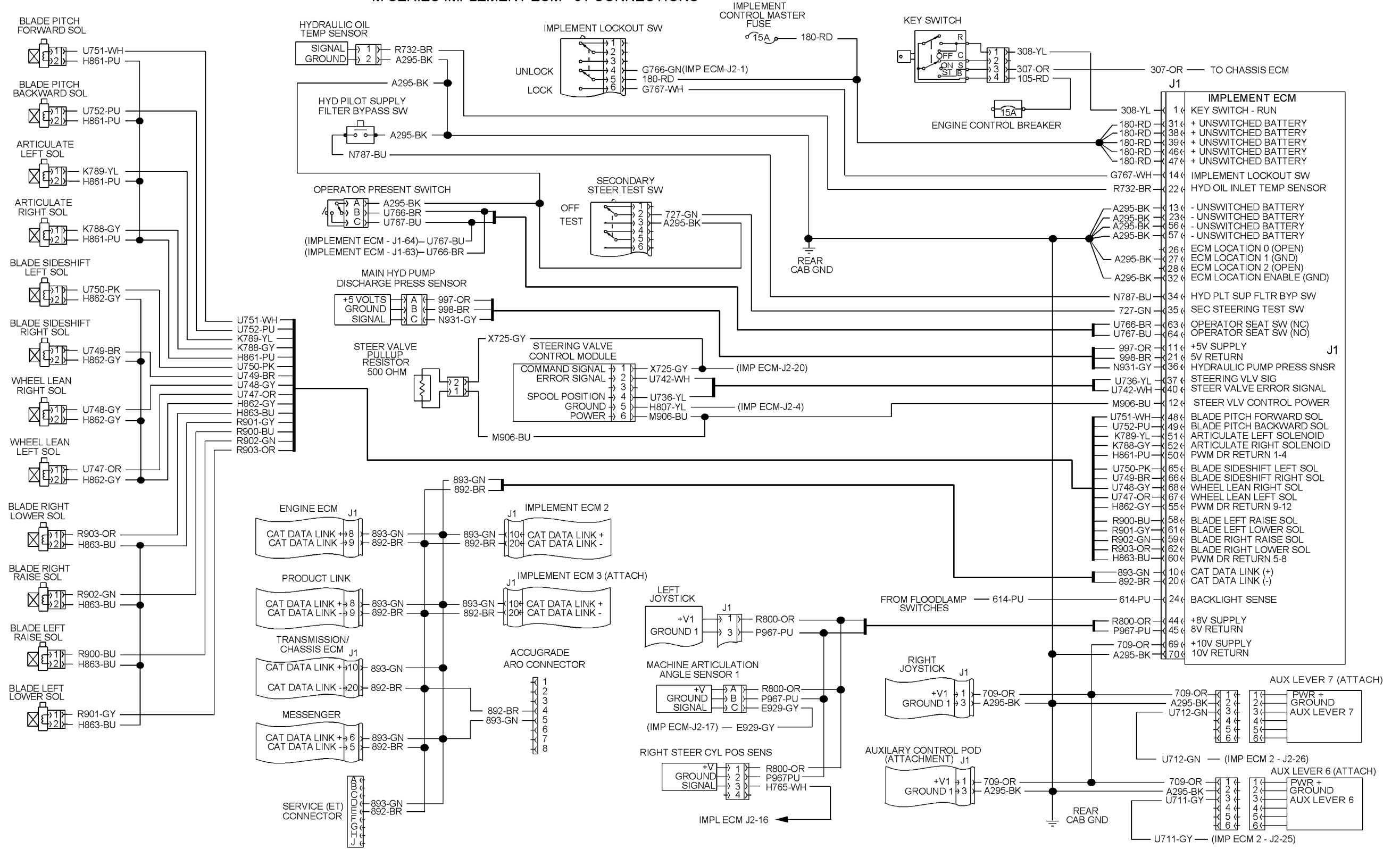

Illustration 573

M SERIES IMPLEMENT ECM 2 - J1 AND J2 CONNECTIONS

NOTE: FOR JOYSTICK ATTACHMENT REFER TO ADVANCED CONTROL JOYSTICK

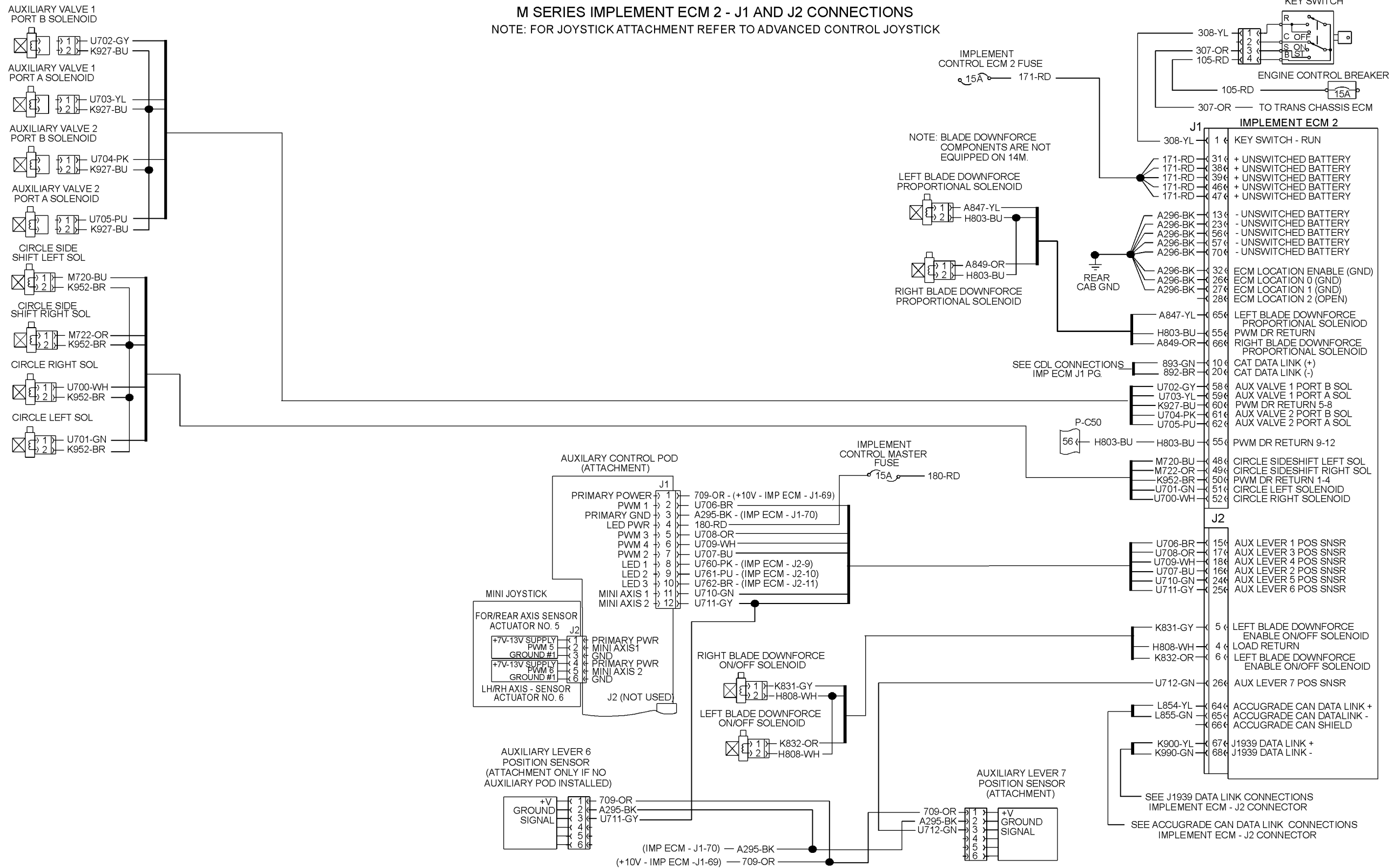

Illustration 575

The following simplified electrical schematics for the M Series Motor Graders Implement Electronic Control System are electrically correct. The schematics show the input connections and the output connections for the J1 and the J2 connectors on the Implement ECM, the Implement ECM 2, and the Implement ECM 3.

The schematics do not show all possible harness connectors. The schematics do not show all related electrical systems on the machine. For a complete electrical system schematic of a particular machine, always refer to the Electrical System Schematic in the Service Manual for your machine.

Testing and Adjusting

M SERIES IMPLEMENT ECM - J1 CONNECTIONS

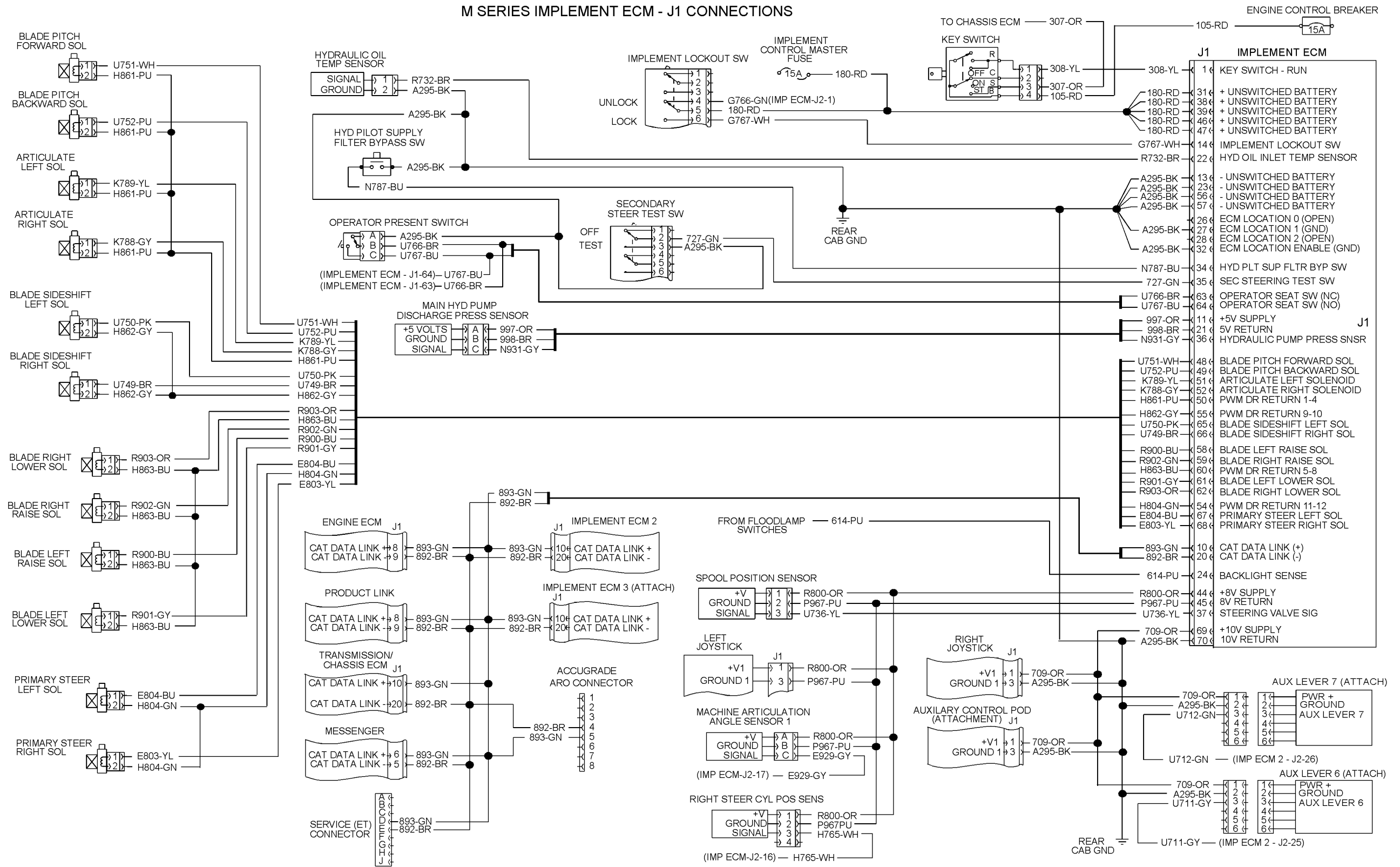

Testing and Adjusting

M SERIES IMPLEMENT ECM - J2 CONNECTIONS

NOTE: FOR JOYSTICK ATTACHEMENT REFER TO ADVANCED CONTROL JOYSTICK SCHEMATIC

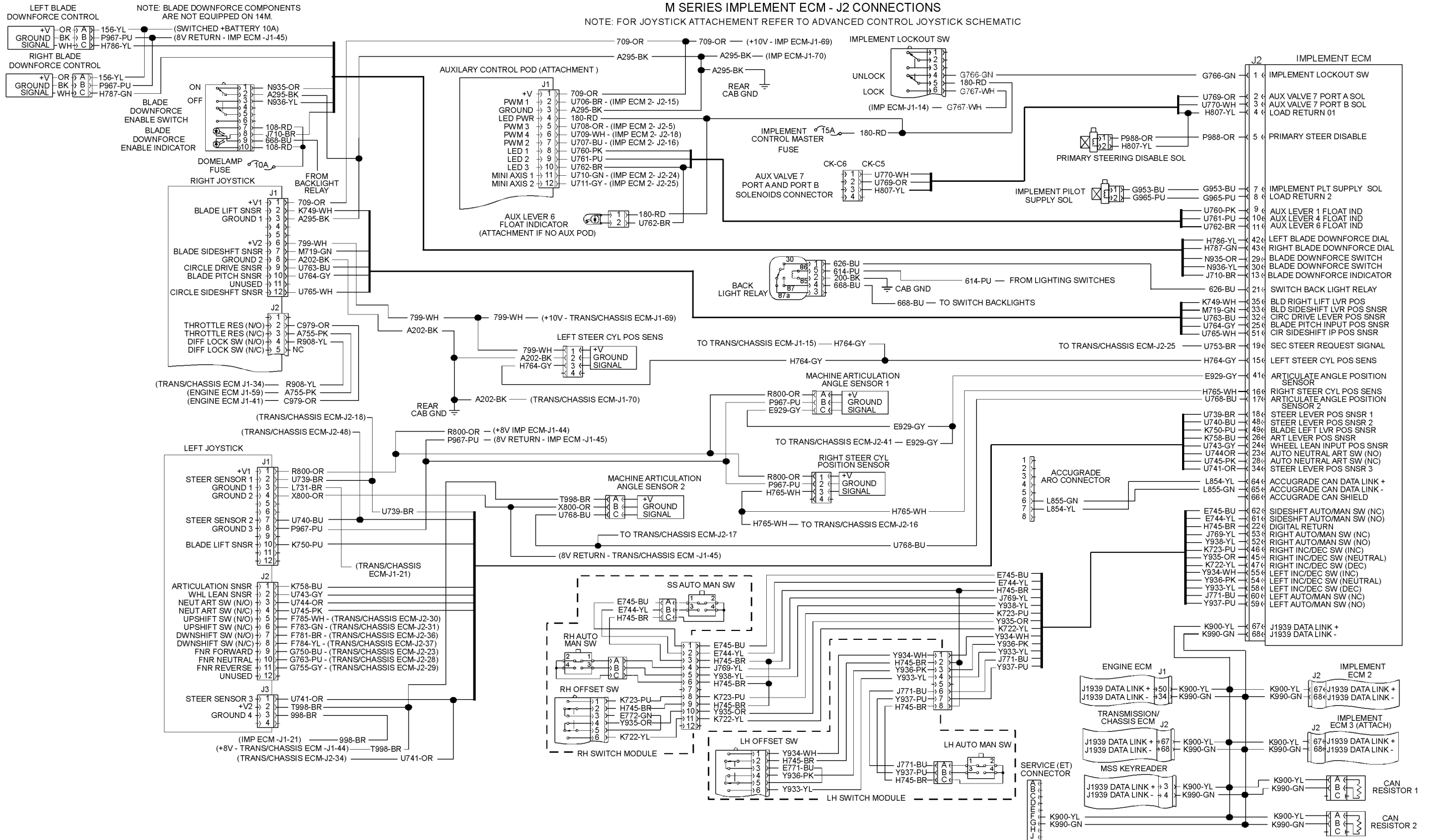
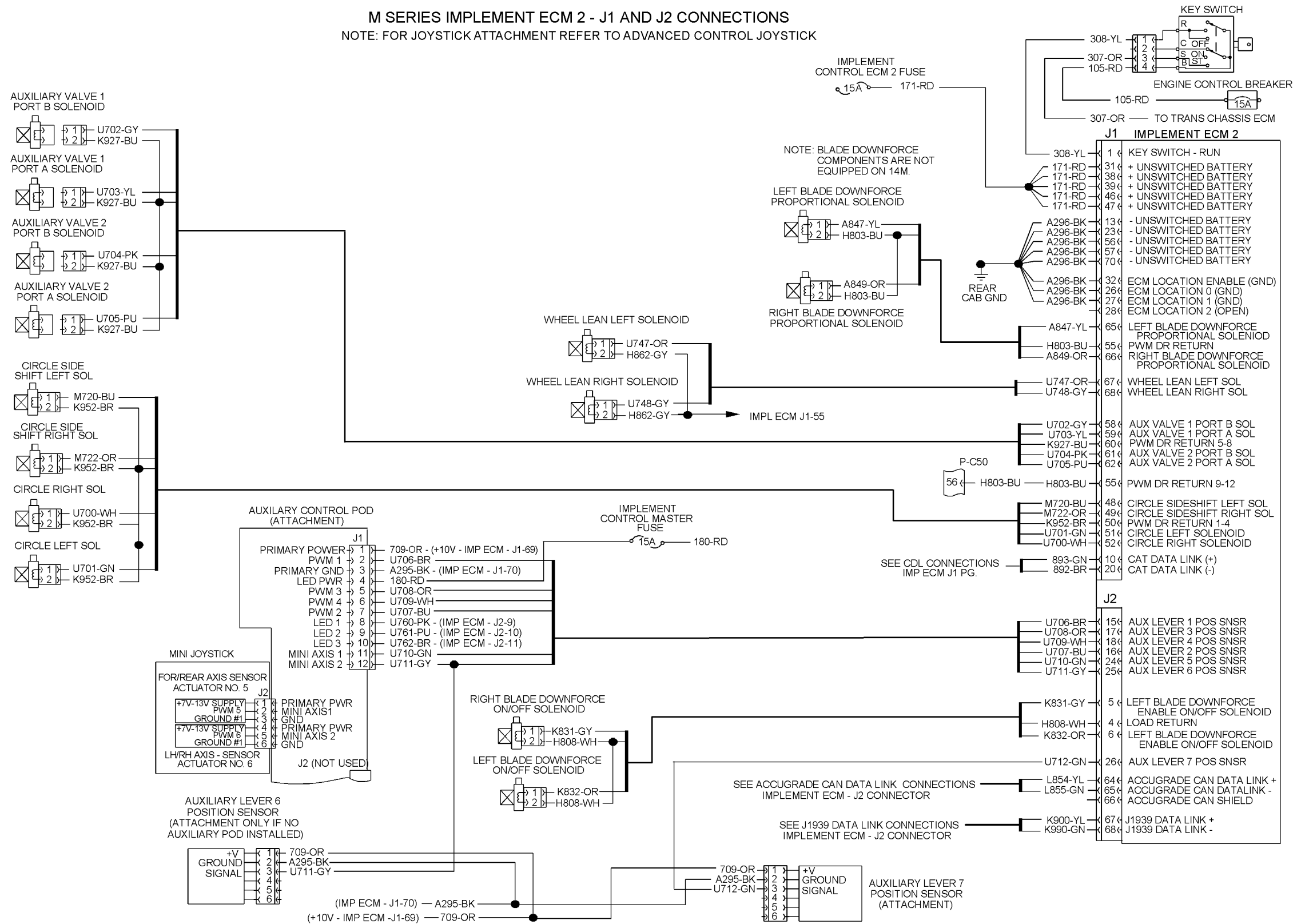

Illustration 579

M SERIES IMPLEMENT ECM 2 - J1 AND J2 CONNECTIONS
 NOTE: FOR JOYSTICK ATTACHMENT REFER TO ADVANCED CONTROL JOYSTICK



M SERIES IMPLEMENT ECM 3 - J1 AND J2 CONNECTIONS

